



High Intensity Housed Bullet Magnets



Housed Bullet Magnets are ideal for the removal of tramp iron, for example, nuts, bolts, washers, staples etc. from air blown or gravity fed pipelines. The magnets are generally installed at ingredient intake points and the primary stages of the process line.

The unit is designed to prevent tramp iron from damaging expensive process machinery, for example, mixers, blenders and screw feed conveyors. A high intensity magnetic bullet element is centrally mounted within a stainless steel housing. The design ensures that product flow is unaffected by the magnetic element.

The bullet incorporates Rare Earth Neodymium Iron Boron magnetic material which generates deep penetrating magnetic flux fields ensuring

ferrous contamination is captured whilst the angled nose cone assists in maintaining product integrity and flow during high speed product processing. Any attracted contamination finds sanctuary beneath the catchment ledges preventing 'wash off'.

To facilitate the removal of collected contamination the flow of product must be stopped or temporarily diverted from the magnet. Opening the access door, swings the door mounted bullet away from the housing to enable cleaning to be carried out, therefore preventing any potential danger of re-introducing contamination back into the process line. Larger bullet elements are mounted on a sliding carriage to facilitate the cleaning process.

Main features and benefits:

- High intensity flux fields are emitted from the pole concentrators generating in excess of 9000 Gauss.
- Housings designed to operate at 0.8 bar pressure.
- Inlet and outlet flanges to suit your process line, please state at time of order.
- Double action swing away hinged door for greater accessibility.
- Provides ultimate protection from a wide range of product contaminants.
- Totally maintenance free (apart from cleaning), no power supply, no running costs.
- Quick and easy to install. Once in position, you know its definitely working.
- Supplied with full test certificates.
- Guarantee on magnetic performance.



Technical Specifications

Eclipse Magnetics has a full range of magnetic separators to cover all applications. Many separators can be tailor made to exactly suit existing process pipeline and duct work.

Magnetic Performance: High strength 9,000 Gauss

Magnetic Material: High Energy 'Rare Earth' Neodymium Iron Boron.

Material Specification: Housing 316 grade Stainless Steel.
Pole concentrators polished and plated mild steel.

Finish: Polished.

Limitations: High Intensity Bullet Magnets should not be exposed to temperatures in excess of 100 °C (212 °F).

Maximum operating pressure 0.8 bar.

Part No.	Dia. A (mm)	Dia. B (mm)	C (mm)	D (mm)	Dia. E (mm)	Weight (kg)
HBM075	75	200	490	185	75	16
HBM100	100	225	490	185	100	22
HBM125	125	250	550	240	125	33
HBM150	150	275	550	250	150	46
HBM200	200	325	640	325	200	105

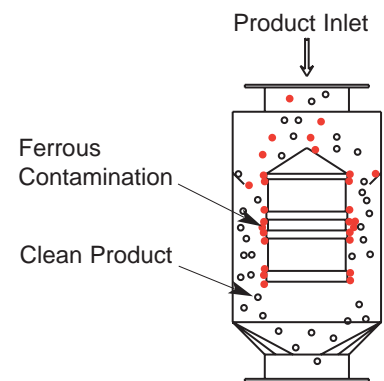

NB.

When ordering please specify flange details.

Special Bullet Magnets are available which can withstand extreme temperatures of up to 350 °C (662 °F).

Units that can withstand higher operating pressures are available on request.

For special applications please call our Technical Department for advice.

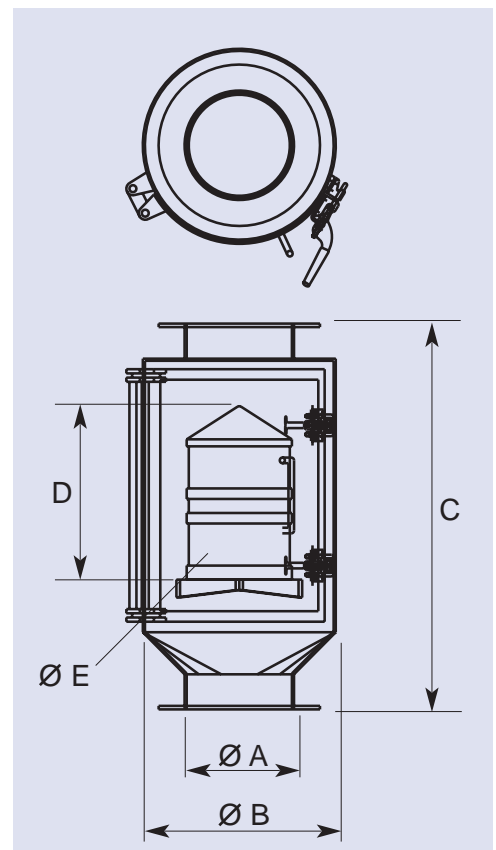

If it's Magnetic

....Then it's Eclipse Magnetics

Eclipse Magnetics Ltd - Separation Division
Units 1-4 Vulcan Road, Sheffield, S9 1EW, England

Tel: 0114 225 0500
Fax: 0114 225 0525