

Ingredient sieve



Ingredient Sieve 450 & 600 series



Foreign Body Removal

Eclipse Magnetics provides the products and expertise to protect your customers and your business from the expense and damage that metal contamination can cause.

Eclipse Magnetics ingredient sieves, magnetics separators and metal detectors are used to protect almost all types of process line and product.

Implementing a full Foreign Body Removal (FBR) programme not only prevents contaminated product from reaching your customers but also protects process machinery from damage and can warn of potential problems, preventing machine failure and reducing downtime.

Eclipse Magnetics has ATEX 'type' approval which means it can supply ATEX certified units direct from its factory in Sheffield, England, cutting lead time and cost.

To ensure your process conforms to BRC/IFS requirements, and that you are fully protected from the damage metal contamination can cause, contact us for a free site survey:

enquiries@eclipse-magnetics.co.uk

The sieve

Stainless steel construction

Fully constructed from highly-polished 316 stainless steel: long-lasting, hard-wearing and suitable for all products.

Top pan

Bespoke top pan available on request.

Metal detectable seal

The seal is made from hard-wearing patented metal-detectable material.

Electrical control box

Incorporating isolation switch and on / off push button.

Motor

Fitted with an ultra-quiet electro-mechanical drive motor with a running noise of 70dB(A).

Easy to move

The sieve is supported on a wheeled trolley allowing ease of movement. It is stable in use and doesn't have the inconvenience of wheel locks. The power cable can be removed from the unit.

Custom support trolley

The support trolley can be manufactured to your specification.



High-quality removable screen

Grades product and removes debris.

The screen is made from high-grade austenitic stainless steel wire mesh ensuring any debris from wear or sudden failure is removed by the sieve magnet.

450 and 600mm diameter screens available



Magnetic grid

High-intensity rare-earth rods ensure that all ferrous and para-magnetic contamination is removed from the screened product.



Technical information measurements are nominal

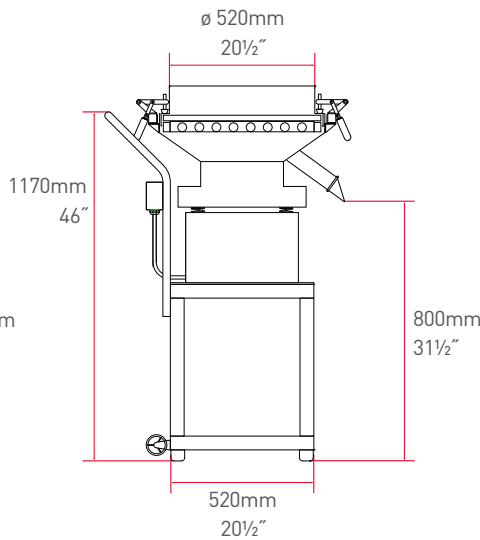
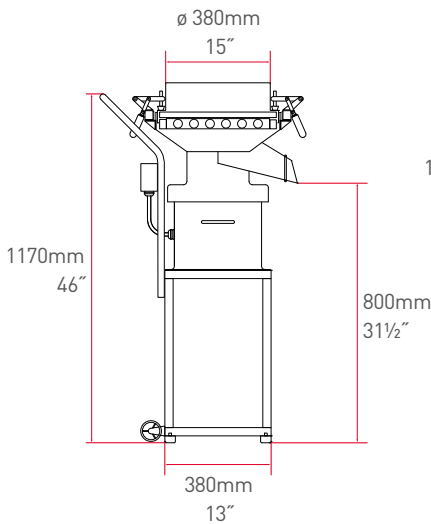
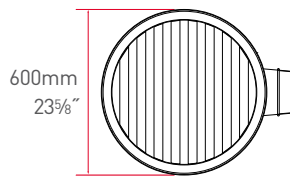
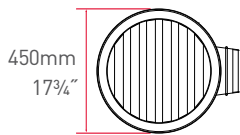

FBR Product Range



Magnetic separators



Metal detectors



X-ray machines

Representative:

www.eclipse-magnetics.co.uk

Eclipse Magnetics Ltd
 Atlas Way, Atlas North, Sheffield, S4 7QQ, England
 T +44 (0)114 225 0600 F +44 (0)114 225 0525
 enquiries@eclipse-magnetics.co.uk www.eclipse-magnetics.co.uk



While every effort has been made to ensure the accuracy of the information in this publication please note that specifications may change without notice.

Worldwide

UK and Ireland

contact: **Michael Atkins**
 T +44 (0)114 225 0550
 F +44 (0)114 225 0525
 enquiries@eclipse-magnetics.co.uk

Europe

contact: **Laurent Pirez**
 T/F +33 (0)3 20 17 26 91
 lpirez@eclipsemagnetics.com

Americas

Eclipse Tools North America Inc.
 442 Millen Road, Unit #9, Stoney Creek
 Ontario, L8E 6H2, Canada

contact: **Mark Ward**
 T 1-800-260-2124
 T 905-664-5585
 F 905-664-7090
 mward@eclipsetoolsinc.com

Australasia / Asia

contact: **John Dargavel**
 T +44 (0)114 225 0606
 F +44 (0)114 225 0610
 jdargavel@eclipsemagnetics.com

Middle East

contact: **Einstein Chan**
 T +44 (0)114 281 4373
 F +44 (0)114 225 0525
 echan@eclipse-magnetics.co.uk