

BoilerMag **XT**[™]

THE ORIGINAL MAGNETIC FILTER

For industrial & commercial heating and cooling systems



**3 YEAR
WARRANTY**

**Prevents build
up of black
sludge**

BoilerMag magnetic filter

BLACK SLUDGE – the enemy within

The natural build up of black sludge (iron oxide) in heating or cooling systems significantly reduces performance and efficiency. It can also cause premature valve and pump failure, damage to the boiler and even full system breakdown.

BoilerMag prevents these problems by removing the damaging black iron oxide.

As water circulates through the system it flows through the BoilerMag. Iron oxide contamination is attracted to the magnetic rods and is removed from circulation. BoilerMag removes the smallest particles, down to sub-micron size.

Benefits of BoilerMag

- Guaranteed protection from black iron oxide
- Easy installation and maintenance
- Maintains peak performance of systems
- Improves energy efficiency
- Extends system life
- No running costs, minimal maintenance costs
- Reduces the sludge that builds up in boilers
- Industry leading 3 year warranty

Engineered to last

The BoilerMag has a full stainless steel housing precision manufactured to ISO 9001:2009. It is available in 3 sizes to fit 2", 4" and 6" pipes with PN 16 flanges.

The units are fitted with high intensity rare earth magnetic rods.

BoilerMag IN USE

It removes black sludge, improving system performance and reducing maintenance.

Installation

BoilerMag is typically installed on the return circuit as close to the boiler as possible. On larger systems smaller units may be installed elsewhere giving extra protection for radiators and pipework.



Inspection

A sight glass in the casing allows inspection of contamination build up.

Cleaning

Cleaning is simple: isolate the inlet and outlet valves and release the nuts on the lid. Remove the contaminated cartridge from the housing and remove the magnetic cores from the tube assembly. The attracted contamination can then be removed, quickly and easily.

Installation options

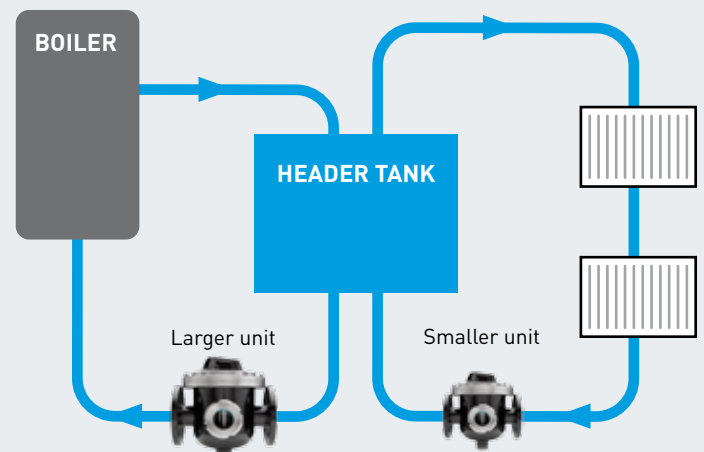



Problem systems

A system suffering any of the following problems may be affected by iron oxide build up and can benefit from the installation of BoilerMag filtration:

- Radiator cold spots
- Poor circulation
- Blocked pipes and radiators
- Excessive noise
- Inefficient operation
- Frequent breakdowns
- Premature pump wear



Contamination attached to the 9,000 Gauss magnetic cores



Where to install BoilerMag

Most larger buildings can benefit from the installation of BoilerMag:

- Factories
- Offices
- Housing estates, flats
- Hospitals
- Leisure centres
- Educational establishments
- Community buildings
- Churches
- Retail premises
- Banks

Product data

BoilerMag Filter
Magnetic filtration for industrial & commercial heating and cooling systems

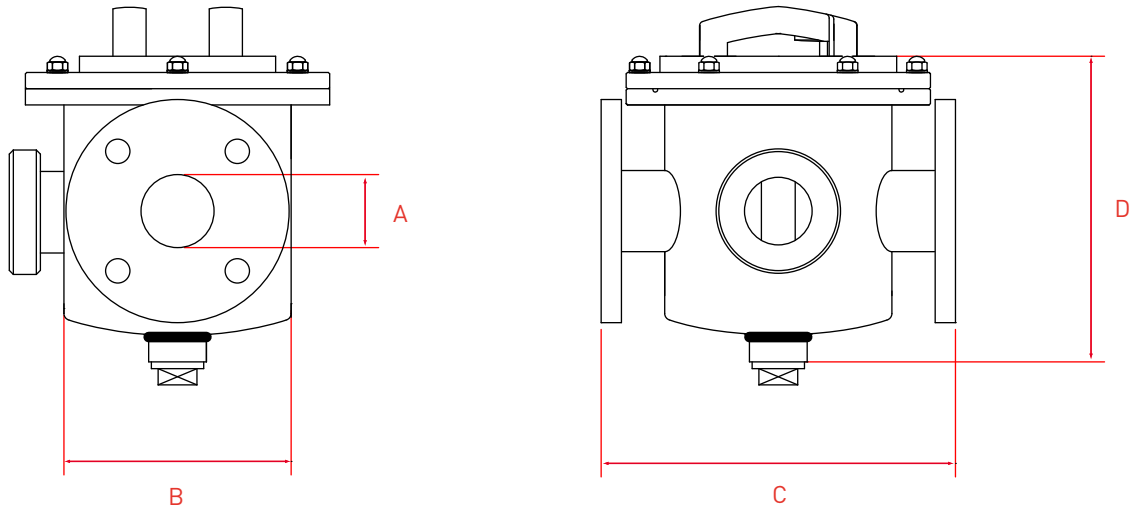

Part No.	Inlet / Outlet Dia. A	Filter Dia. B	Flange spacing C	Height D	No. magnetic rods	Flow rate cubic metres/hour	Flange type
BMXT150	2"	170	260	225	5	18	PN16
BMXT200	4"	220	360	280	7	70	PN16
BMXT300	4"	325	470	345	9	80	PN16
BMXT300HF	6"	325	470	365	9	100	PN16

all dimensions in mm unless stated

Performance

Magnetic performance	9,000 Gauss high strength
Performance reading	On tube surface
Magnetic material	Rare earth neodymium iron boron
Magnet grade	N42SH – inspected and confirmed by hystergaph prior to use
Temperature	5° to 150°C
Operating pressure	+/- 6 bar

Materials

Housing	304 grade stainless steel
Tube cartridge	316 grade stainless steel – aerospace quality
Other parts	304 grade stainless steel
Surface finish	Internal - bead blast External - powder coated, black
Sealing	Viton o-ring, brown
Viewing glass	Toughened soda lime to BS3463

Options

Dual viewing glass – opposite each other
High temperature samarium cobalt magnetic material +250° C

Warranty

Industry leading 3 years

Eclipse Magnetics Ltd

Atlas Way, Atlas North, Sheffield, S4 7QQ, England
T +44 (0)114 225 0600 F +44 (0)114 225 0525
info@eclipsemagnetics.com www.eclipsemagnetics.com

