

# Strip Magnet

High Intensity – Rare Earth



Data Sheet No 507

## Product Data:-



### **Preface:**

Rare Earth strip magnets are versatile and can be utilised in various processes. These units are usually installed above transfer conveyors and vibratory feeders to attract 'tramp' type contamination and any loose machinery that has fallen off during the manufacturing or packaging stages.

The unit consists of two rows of magnetic material running the full length of the unit. It is these rows of magnets that generate the high intensity magnetic flux fields, which reach approx 85mm from the units front face. Due to the design, magnetism is only present on one face ensuring that no surrounding sensitive process machinery is affected.

'Tramp' contamination can be attracted from the conveyor surface even when trapped underneath the product e.g. biscuit etc. Due to the units, full Stainless Steel construction water and chemical clean down can be carried out.

### **Cleaning:**

Due to the strip magnet being highly visible once installed, any attracted contamination can be easily seen. In most cases this contamination can be removed by hand. In high collection installations a simple scraper can be used. Working with the maintenance department any attracted machinery parts can be quickly identified and corrective maintenance carried out.

### **Suitable Products:**

All conveyed products less than 85mm thick.

### **Suitable Locations:**

Above transfer belt conveyors and vibratory feeders.

### **Benefits:**

- Suitable for wash down
- High collection capacity
- Removes 'tramp' sized contaminants
- Rare Earth deep magnetic field
- Easy to clean

### **Category:**

Primary.



# Strip Magnet

High Intensity – Rare Earth



## Technical Data:-

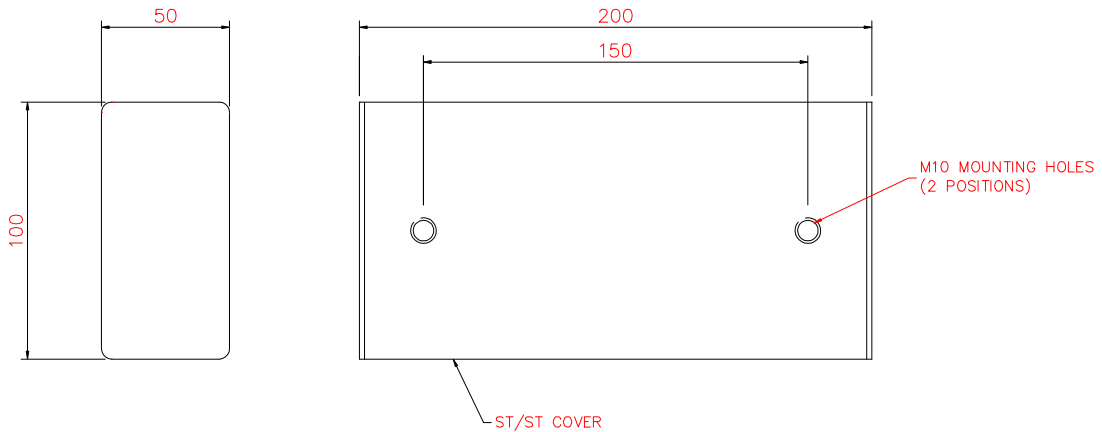

### Sizes:-

Part No	A Length (mm / " )	No. Of Holes	B Centres	Weight Kgs
SMN100	100 / 4"	2	50	2.5
SMN200	200 / 8"	2	150	5.0
SMN300	300 / 12"	2	200	7.5
SMN400	400 / 16"	2	200	10.0
SMN500	500 / 20"	3	200	12.5
SMN600	600 / 24"	3	200	15.0
SMN700	700 / 28"	4	200	17.5
SMN800	800 / 32"	4	200	20.0
SMN900	900 / 36"	5	200	22.5
SMN1000	1000 / 40"	5	200	25.0

All dimensions in mm

### Performance:-

<b>Magnetic Performance:</b>	4,000 Gauss
<b>Performance Reading:</b>	On magnetic front face
<b>Magnetic Field Depth:</b>	85mm – Using 5mm Ø 25mm long mild steel test piece
<b>Magnetic Material:</b>	Rare Earth Neodymium Iron Boron
<b>Magnet Grade:</b>	N35 – Inspected & confirmed via hysteresis prior to use
<b>Temperature:</b>	-20° C/ + 90° C

### Materials:-

<b>Housing:</b>	304 Grade Stainless Steel
<b>Other Parts:</b>	304 Grade Stainless Steel
<b>Surface Finish:</b>	Brushed to 2.0µm

### Options:-

High temperature Samarium Cobalt magnetic material, + 250° C  
 Length up to 2000mm long  
 316 Grade Stainless Steel  
 ATEX certified  
 Ceramic magnetic material  
 Pharmaceutical specification

